

**4.** Use a 3/8" drill bit to drill four holes in your trailer rail as marked.

**5.** Assemble the uprights to the trailer with four 3/8-16 x 1-1/4" cap screws, eight 3/8" flat washers and four 3/8-16 nylock nuts.

**For steps 6-10 refer to Figure 2.**

**6.** Attach a lanyard with the 1.5" loop to the each of the six lock pin handles by folding the end of the lanyard over and snapping it together.

**7.** Attach the three hair pin cotters to three lanyards by inserting the pins into the lanyard .26" eye.

**8.** Attach the three locks to three lanyards by inserting the lock bolt into the .26" lanyard eye.

**9.** Select one upright to be the locking upright and assemble three lock pins and locks as follows:

- A.** Insert the end of the lock lanyard through the 1.5" loop of the lock pin lanyard and through the rectangular hole in the side of the lock plate.
- B.** Snap closed the lock lanyard around both the lock plate and the 1.5" loop of the lock pin lanyard.

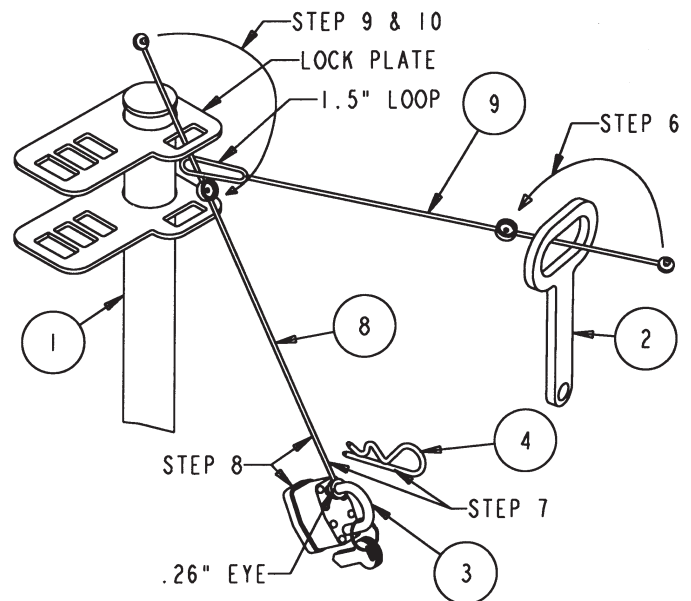

FIGURE 2  
 LANYARD ASSEMBLY

**10.** Assemble the remaining lock pins and three hair pin cotters to the other upright as follows:

- A.** Insert the end of the hair pin lanyard through the 1.5" loop of the lock pin lanyard and through the rectangular hole in the side of the lock plate.
- B.** Snap closed the hair pin lanyard around both the lock plate and the 1.5" loop of the lock pin lanyard.

### Warranty

Buyers Products Co. warrants all truck/trailer hardware manufactured or distributed by it, to be free from defects in material and workmanship for a period of one year from date of shipment. Parts must be properly installed and used under normal conditions. Any product which has been altered, including modification, misuse, accident or lack of maintenance will not be considered under warranty. Normal wear is excluded. The sole responsibility of Buyers Products Co. under this warranty is limited to repairing or replacing any part or parts which are returned, prepaid, and are found to be defective by Buyers Products Co. Authorization from Buyers Products Co. must be obtained before returning any part. No charges for transportation or labor performed on Buyers' products will be allowed under this warranty.

# .....Installation Instructions.....

## LT13 Line Trimmer Rack

for Open Utility Landscape Trailers

Before you begin installing:

1. Read and understand these instructions completely.
2. Verify that you have received all the parts listed in the bill of materials.

### Tools Required:

- (2) 9/16" Wrenches and/or Sockets
- Electric Drill
- (1) 3/8" Drill Bit
- Tape Measure
- Box Knife

### CAUTION

Always wear safety glasses when using power tools.

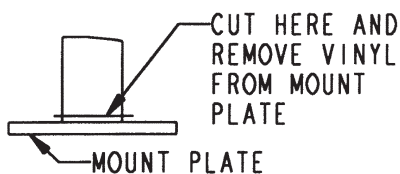
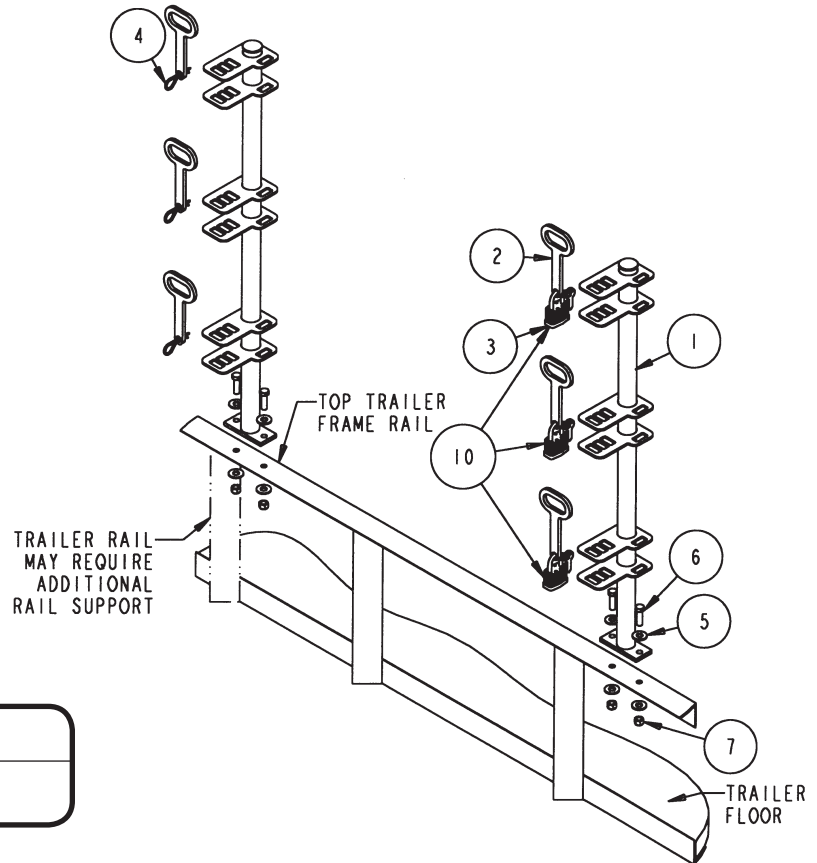

FIGURE 1 - VINYL REMOVAL

1. Prepare the trimmer rack uprights for mounting by removing the vinyl coating from the top and bottom of the mounting plates. See figure 1.

2. Determine the mounting position for the trimmer rack uprights on the trailer rail. The uprights should be about 36" apart. The handle of the line trimmer should be located in one of the upright channels. Note: If bent shaft trimmers are used, the uprights need to be mounted closer together than if straight shaft trimmers are used.



### Bill of Materials

ITEM	PART NO.	QTY.	DESCRIPTION
1	3006287	2	Upright, Trimmer Rack
2	3006160	6	Lock Pin, Trimmer Rack
3	-	3	Lock, 1½" Pad w/Keys
4	-	3	Pin, Hair Cotter
5	-	8	Washer, Flat 3/8" USS Zinc
6	-	4	Screw, HHC 3/8-16 x 1¼ Gr 5 Zinc
7	-	4	Nut, Nylock 3/8-16 x 7/16 Zinc
8	3006439	7	Lanyard, Nylon, 10" w/.26" Eye
9	3006438	7	Lanyard, Nylon, 10" w/1½" Loop
10	3006320	1	Lock Kit, Three 1½" Locks keyed alike

3. After determining the position of the uprights, mark the centers of the two holes in each upright mounting plate on the upper trailer rail. Warning! Check for locations of brake lines and electrical wiring etc., before drilling any holes. Any damage to trailer during installation is installer's full responsibility.